

Dual Common-Cathode High-Voltage Schottky Rectifier

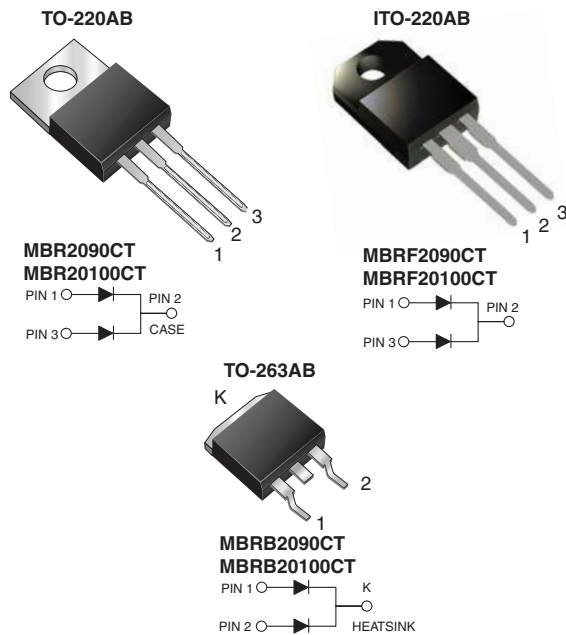

FEATURES

- Guardring for overvoltage protection
- Lower power losses, high efficiency
- Low forward voltage drop
- High forward surge capability
- High frequency operation
- Meets MSL level 1, per J-STD-020C, LF max peak of 245 °C (for TO-263AB package)
- Solder Dip 260 °C, 40 seconds (for TO-220AB & ITO-220AB package)
- Component in accordance to RoHS 2002/95/EC and WEEE 2002/96/EC



TYPICAL APPLICATIONS

For use in high frequency rectifier of switching mode power supplies, free-wheeling diodes, dc-to-dc converters or polarity protection application.

MECHANICAL DATA

Case: TO-220AB, ITO-220AB, TO-263AB

Epoxy meets UL 94V-0 flammability rating

Terminals: Matte tin plated leads, solderable per J-STD-002B and JESD22-B102D

E3 suffix for commercial grade

Polarity: As marked

Mounting Torque: 10 in-lbs maximum

MAJOR RATINGS AND CHARACTERISTICS

| | |
|-------------------|-------------|
| $I_{F(AV)}$ | 10 A x 2 |
| V_{RRM} | 90 V, 100 V |
| I_{FSM} | 150 A |
| V_F | 0.65 V |
| $T_j \text{ max}$ | 150 °C |

MAXIMUM RATINGS ($T_C = 25 \text{ °C}$ unless otherwise noted)

| PARAMETER | SYMBOL | MBR2090CT | MBR20100CT | UNIT |
|---|----------------|---------------|------------|------------------|
| Maximum repetitive peak reverse voltage | V_{RRM} | 90 | 100 | V |
| Working peak reverse voltage | V_{RWM} | 90 | 100 | V |
| Maximum DC blocking voltage | V_{DC} | 90 | 100 | V |
| Maximum average forward rectified current at $T_C = 133 \text{ °C}$ Total device per diode | $I_{F(AV)}$ | 20 10 | | A |
| Peak forward surge current 8.3 ms single half sine-wave superimposed on rated load per diode | I_{FSM} | 150 | | A |
| Peak repetitive reverse current per diode at $t_p = 2 \text{ }\mu\text{s}$, 1 kHz | I_{RRM} | 0.5 | | A |
| Voltage rate of change (rated V_R) | dv/dt | 10000 | | V/ μs |
| Operating junction and storage temperature range | T_J, T_{STG} | - 65 to + 150 | | °C |
| Isolation voltage (ITO-220AB only) From terminal to heatsink $t = 1 \text{ minute}$ | V_{AC} | 1500 | | V |

| ELECTRICAL CHARACTERISTICS ($T_C = 25\text{ }^\circ\text{C}$ unless otherwise noted) | | | | |
|--|---|--------|-------|---------------|
| PARAMETER | TEST CONDITIONS | SYMBOL | VALUE | UNIT |
| Maximum instantaneous forward voltage per diode ⁽¹⁾ | $I_F = 10\text{ A}$, $T_C = 25\text{ }^\circ\text{C}$ | V_F | 0.80 | V |
| | $I_F = 10\text{ A}$, $T_C = 125\text{ }^\circ\text{C}$ | | 0.65 | |
| | $I_F = 20\text{ A}$, $T_C = 25\text{ }^\circ\text{C}$ | | 0.95 | |
| | $I_F = 20\text{ A}$, $T_C = 125\text{ }^\circ\text{C}$ | | 0.75 | |
| Maximum reverse current per diode at working peak reverse voltage ⁽¹⁾ | $T_J = 25\text{ }^\circ\text{C}$ | I_R | 100 | μA |
| | $T_J = 100\text{ }^\circ\text{C}$ | | 6.0 | mA |

Note:

(1) Pulse test: 300 μs pulse width, 1 % duty cycle

| THERMAL CHARACTERISTICS ($T_C = 25\text{ }^\circ\text{C}$ unless otherwise noted) | | | | | |
|---|-----------------|-----|------|------|--------------------|
| PARAMETER | SYMBOL | MBR | MBRF | MBRB | UNIT |
| Typical thermal resistance per diode | $R_{\theta JA}$ | 60 | - | 60 | $^\circ\text{C/W}$ |
| | $R_{\theta JC}$ | 2.0 | 3.5 | 2.0 | |

| ORDERING INFORMATION (Example) | | | | | |
|---------------------------------------|-------------------|-----------------|--------------|---------------|---------------|
| PACKAGE | PREFERRED P/N | UNIT WEIGHT (g) | PACKAGE CODE | BASE QUANTITY | DELIVERY MODE |
| TO-220AB | MBR20100CT-E3/45 | 1.85 | 45 | 50/Tube | Tube |
| ITO-220AB | MBRF20100CT-E3/45 | 1.99 | 45 | 50/Tube | Tube |
| TO-263AB | MBRB20100CT-E3/45 | 1.35 | 45 | 50/Tube | Tube |
| TO-263AB | MBRB20100CT-E3/81 | 1.35 | 81 | 800/Reel | Tape Reel |

RATINGS AND CHARACTERISTICS CURVES

($T_A = 25\text{ }^\circ\text{C}$ unless otherwise noted)

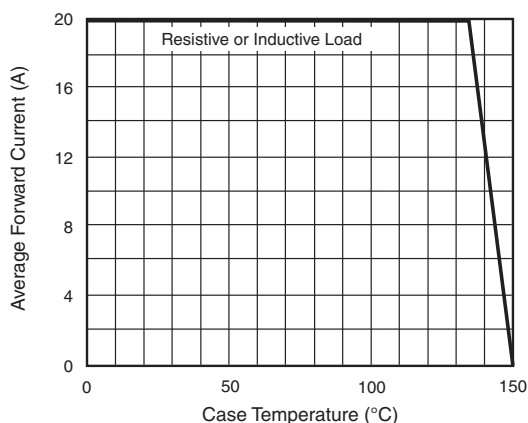

Figure 1. Forward Current Derating Curve

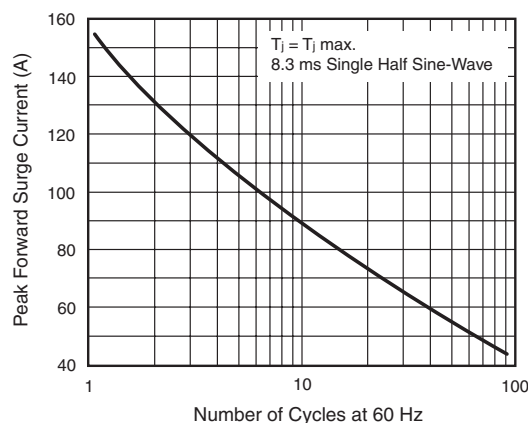

Figure 2. Maximum Non-Repetitive Peak Forward Surge Current Per Diode

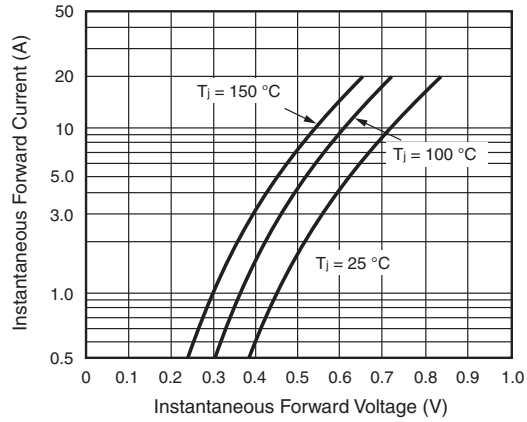

Figure 3. Typical Instantaneous Forward Characteristics Per Diode

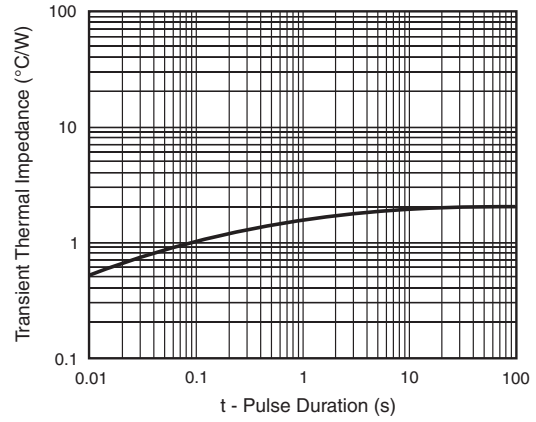

Figure 5. Typical Transient Thermal Impedance Per Diode

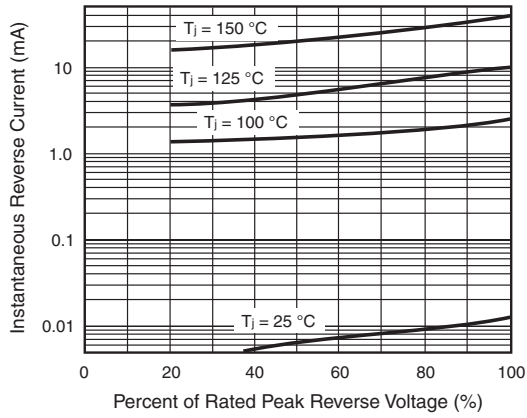

Figure 4. Typical Reverse Characteristics Per Diode

MBR(F,B)2090CT & MBR(F,B)20100CT

Vishay General Semiconductor



PACKAGE OUTLINE DIMENSIONS in inches (millimeters)

TO-220AB

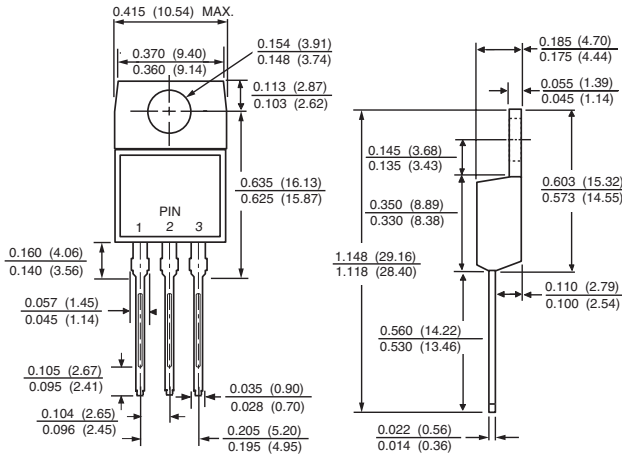

ITO-220AB

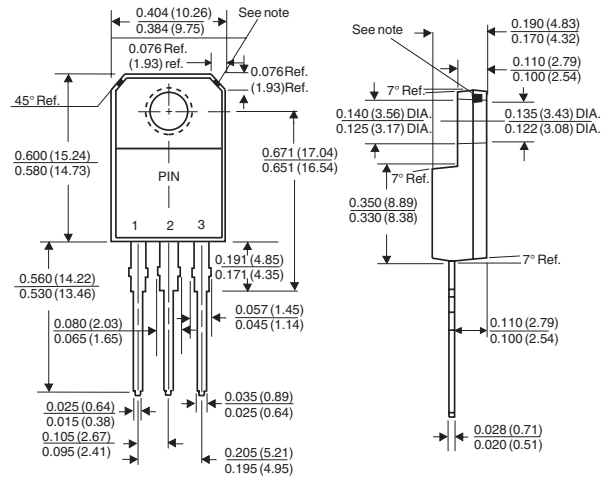

Note: Copper exposure is allowable for 0.005 (0.13) max. from the body

TO-263AB

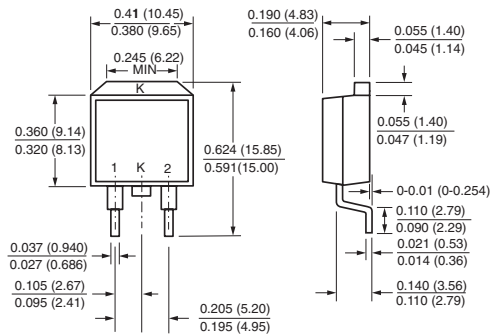

Mounting Pad Layout

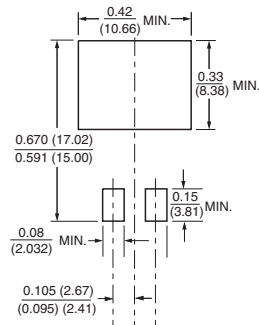



Notice

Specifications of the products displayed herein are subject to change without notice. Vishay Intertechnology, Inc., or anyone on its behalf, assumes no responsibility or liability for any errors or inaccuracies.

Information contained herein is intended to provide a product description only. No license, express or implied, by estoppel or otherwise, to any intellectual property rights is granted by this document. Except as provided in Vishay's terms and conditions of sale for such products, Vishay assumes no liability whatsoever, and disclaims any express or implied warranty, relating to sale and/or use of Vishay products including liability or warranties relating to fitness for a particular purpose, merchantability, or infringement of any patent, copyright, or other intellectual property right.

The products shown herein are not designed for use in medical, life-saving, or life-sustaining applications. Customers using or selling these products for use in such applications do so at their own risk and agree to fully indemnify Vishay for any damages resulting from such improper use or sale.